

All holes go all the through.

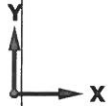
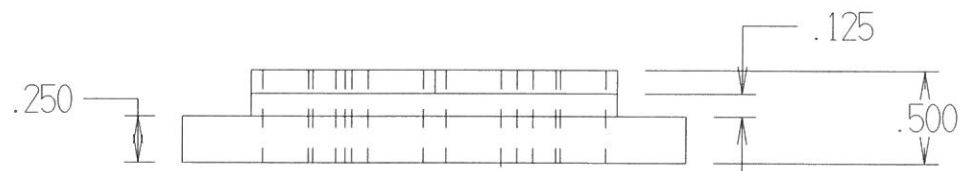
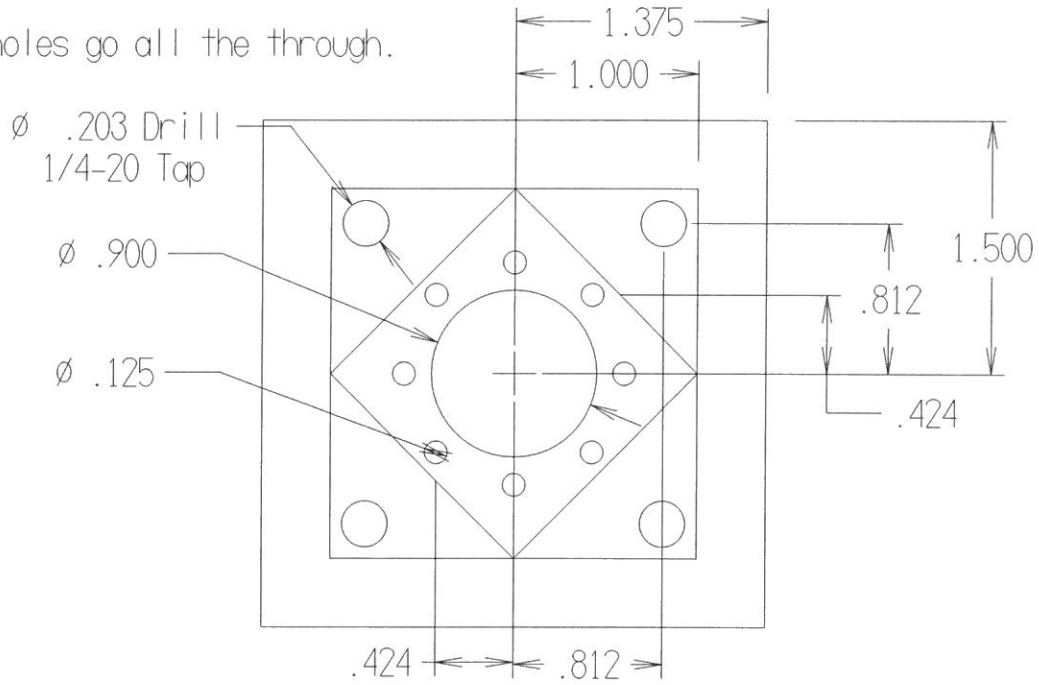

TOLERANCES		SWIC CNC	
.X	= +/- .010	PART: Hole Plate	
.XX	= +/- .005	DRAWN BY:	HRS.: 10
.XXX	= +/- .003	MATERIAL: Steel	
.XXXX	= +/- .0005	DATE:	
FRACTIONAL = +/- 1/64			

Top

1.0488 in
Inch